

PANIMALAR ENGINEERING COLLEGE

(An Autonomous Institution, Affiliated to Anna University, Chennai)

JAISAKTHI EDUCATIONAL TRUST

BANGALORE TRUNK ROAD, VARADHARAJAPURAM,
POONAMALLEE, CHENNAI - 600 123



Department of Electrical and Electronics Engineering



IMPULSE (Technical magazine)

Academic Year 2021-2022



Col. Dr. Jeppiaar, M.A. B.L., Ph.D
Founder and Chairman

Message from secretary and correspondent



Engineers play the most vital and important role in nation building. They create new inventions using best engineered technologies to make human life more comfortable, secure and productive. In modern times, nations which have rich engineering and experienced management domains are flourishing economically and are providing better lives to their people. We have excellent potential to grow in diversified areas and excel in Engineering and Management fields. We need enormous number of engineers and managers to write next story of success.

The essence of Engineering and Management education which has spread in India is a very positive sign not only to cater domestic needs but provide manpower to the entire world and become biggest technically trained community. JAISAKTHI EDUCATIONAL TRUST is a venture contributing to this Endeavour. We have started with full force to play a leading role in providing quality education and careers. We have identified the needs of modern engineering, technology and management education for modern age students, with a vision and mission accompanying transparency, accountability and accessibility which keeps us abreast and also ahead of our competitors.

At the outset I send my greetings to the Editorial Board of IMPULSE'21, for working on a Magazine best in all aspects. We want to provide a complete package of educational services to JET students. I believe this magazine will provide us the benchmark for continued improvement in overall development of the College. This magazine should be a good source of guidance for faculty and coming batches of students in choosing activities of their choice in their future for building their careers. I appreciate the efforts of the Editorial team who have done an excellent job in compiling JET activities over the year and disseminate them through this Magazine as well as on the JET website.

Dr. P. Chinnadurai, M.A., Ph.D
Secretary and Correspondent



Message from Director

“A DREAM COMES TRUE”

It is gratifying to be part of IMPULSE'21 and sketching this message for the consideration by the organizing and participating alumni of PEC as well as budding engineer entrepreneurs. I also thank the alumni for the space provided to express the views.

Alumni of every institution make major contribution to the institution more than any other constituent of the college / institution. They are the pillars for the decades / centuries of growth ahead in time. The complementary part is the assured personal growth to unsealed proportion as every alumnus is identified by the institution tag.

All self-financing Engineering colleges affiliated to various institutions are witnessing the era of three decades of EEE domination, which is presently tapering off. During this era the passed out students manning the needs of the EEE industry have contributed immensely to the “Shining India”. These outstanding students migrated to this green pasture to pursue excellence leaving a side the core engineering area. Such a talent was not available to the societal turn around expected of Tamilnadu and India. The chronicle of academic excellence reveals missing pages of such graduates. As a result, the quality and standard of living in our villages have fallen behind the planned targets. The achievement was concentrated and centered on few cities only in which EEE companies are situated.

My view is that emphasis in placement and career choice should be highly inclusive and identify the components of academic excellence needed to do so. The well placed alumni of this institution should allocate time and money for this yeomen service. I sincerely believe that the forthcoming alumni meet will focus on many of the important issues like the present one.

I wish this meet all success.

Dr. C. Sakthi Kumar M.E., PhD.
Director

Message from HOD



Good things remain good only because they are always scarce. I am glad to pen for this wonderful magazine as an appreciation of the commendable efforts put forth by the team for its grand beginning. The efforts taken to bring about innovative content is appreciable. Content on the various opportunities available in the corporate world and alerts on various student level competitions shall be included hence forth.

EEE is the power Department of the Panimalar Engineering college With the growing demand of Electrical Engineers in the Government and private sectors, the Department is making best efforts to produce highly trained and capable engineers who can take up the challenges of the real world. The quality of academic instructions, conduct guidelines and college activities are designed to produce competent and successful engineers. In the Department, the focus is on preparing professional engineers.

It is my immense pleasure to send this message to the release of this Magazine of our Department. It is indeed a pleasure to see the progress of students at a time, when the country is moving ahead with development plans in Electrical Energy sector. I wish all the students who have involved in bringing out the magazine for their greater success and career ahead.

Dr.S. Selvi M.E., Ph.D
Professor and Head

EDITORIAL BOARD

CHAIRMAN

Dr. P. CHINNADURAI, M.A., Ph.D.,
Secretary and Correspondent

Dr. C. SAKTHIKUMAR, M.E, Ph.D.,
Director

CHIEF EDITORIAL BOARD

Dr. K. MANI, M.E., Ph.D.,
Principal

Dr.S.Selvi , M.E., Ph.D.,
Professor & HOD, EEE

STAFF CO-ORDINATORS

1.Dr.B. Muthuraj
Associate Professor /EEE

2 .Mr.S. Sundaramoorthi
Assistant Professor Grade-1 /EEE

STUDENT CO-ORDINATORS

- 1. VETRY SELVAN K, IV YEAR B**
- 2. VIDHYA G, IV YEAR A**
- 3 ARUN KUMAR B, III YEAR C**
- 4. SUBASREE M K, III YEAR A**
- 5. SATHISH KUMAR M, II YEAR B**
- 6. HARSHNI R II YEAR A**

VISION OF THE DEPARTMENT

“To provide excellence in technical education of electrical and electronics engineering and produce globally competent engineers for the revolution of industry.”

MISSION OF THE DEPARTMENT

- **To Provide good infrastructure and serene environment to our students and faculty members to meet the requirement of electrical and electronics engineering.**
- **To prepare the students through contextual technical education for their career enrichment.**
- **To impart knowledge on core engineering fields through projects, workshops and industry interaction.**
- **To prepare graduates with ethical, social and environmental awareness to demonstrate professionalism in multidisciplinary environment.**

Programme Educational Objectives (PEO)

- PEO 1:** To prepare students to analyze, design and implement basic electrical circuits and power systems using the knowledge of basic science and mathematics.
- PEO 2:** To train students with scientific and engineering knowledge so as to comprehend, analyze, design and create novel products and solutions for real time problems.
- PEO 3:** To prepare students with robust knowledge in core engineering for the betterment of placement, research and higher studies.
- PEO 4:** To inculcate graduates with communication skills, leadership qualities in their profession and adopt to current trends by engaging in lifelong learning.
- PEO 5:** To prepare graduates to demonstrate professionalism with social and ethical values.

PROGRAM OUTCOMES (POs)

- PO 1: Engineering Knowledge :**Apply the knowledge of mathematics, science, engineering fundamentals, and an engineering specialisation to the solution of complex engineering problems.
- PO 2: Problem analysis :**Identify, formulate, research literature, and analyse complex engineering problems reaching substantiated conclusions using first principles of mathematics, natural sciences, and engineering sciences.
- PO 3: Design/development of solutions:** Design solutions for complex engineering problems and design system components or processes that meet the specified needs with appropriate consideration for the public health and safety, and the cultural, societal, and environmental considerations.
- PO 4: Conduct investigations of complex problems:** Use research-based knowledge and research methods including design of experiments, analysis and interpretation of data, and synthesis of the information to provide valid conclusions.
- PO 5: Modern Tool Usage :**Create, select, and apply appropriate techniques, resources, and modern engineering and IT tools including prediction and modelling to complex engineering activities with an understanding of the limitations.
- PO 6: The Engineer and Society :**Apply reasoning informed by the contextual knowledge to assess societal, health, safety, legal, and cultural issues and the consequent responsibilities relevant to the professional engineering practice.
- PO 7: Environment and Sustainability:** Understand the impact of the professional engineering solutions in societal and environmental contexts, and demonstrate the knowledge of need for sustainable development.
- PO 8: Ethics :**Apply ethical principles and commit to professional ethics and responsibilities and norms of the engineering practice.
- PO 9: Individual and Team Work :**Function effectively as an individual, and as a member or leader in diverse teams, and in multidisciplinary settings.
- PO 10:Communication:** Communicate effectively on complex engineering activities with the engineering community and with society at large. Some of them are, being able to comprehend and write effective reports and design documentation, make effective presentations, and give and receive clear instructions.
- PO 11: Project Management and Finance :**Demonstrate knowledge and understanding of the engineering and management principles and apply these to one's own work, as a member and leader in a team, to manage projects and in multidisciplinary environments.
- PO 12: Lifelong learning :**Recognise the need for, and have the preparation and ability to engage in independent and lifelong learning in the broadest context of technological change.

PROGRAM SPECIFIC OUTCOMES(PSOs)

- PSO 1:** Apply the basic knowledge of electrical and electronics engineering to analyze and solve the complex problems in Electrical Machines, Control Systems, Instrumentation, Power Systems and Power Electronic Systems.
- PSO 2:** Design and develop hardware and software requirements to meet the needs of Electric drives, Automation, Power Systems and Embedded systems based industries.
- PSO3:** To take up roles in a team, develop managerial skills, and contributes towards the electrical community globally

HISTORY OF ELECTRICAL ENGINEERING

Electricity development and history are very interesting. However, humankind's knowledge of magnetism and static electricity began more than 2,000 years before they were first recognized to be separate (though interrelated) phenomena. Once that intellectual threshold was crossed – in 1551 – scientists took more bold steps forward (and more than a few steps back) towards better understanding and harnessing these forces. The next 400 years would see a succession of discoveries that have advanced our knowledge of magnetism, electricity and the interplay between them, leading to ever more powerful insights and revolutionary inventions.

This Timeline of History of Electricity highlights important events and developments in these fields from prehistory to the beginning of the 21st century.

A Timeline of History of Electricity

600 BC - Thales of Miletus writes about amber becoming charged by rubbing - he was describing what we now call static electricity.

900 BC - Magnus, a Greek shepherd, walks across a field of black stones which pull the iron nails out of his sandals and the iron tip from his shepherd's staff (authenticity not guaranteed). This region becomes known as Magnesia. .

1600 - William Gilbert, court physician to Queen Elizabeth, first coined the term "electricity" from the Greek word for amber. Gilbert wrote about the electrification of many substances in his "De magnete, magneticis que corporibus". He also first used the terms electric force, magnetic pole, and electric attraction. He also discusses static electricity and invents an electric fluid which is liberated by rubbing.

1678 - Christian Huygens introduces his famous construction and principle, thinks about translating his manuscript into Latin, then publishes it in the original French in 1690. He uses his theory to discuss the double refraction of Iceland Spar. His is a theory of pulses, however, not of periodic waves.

1717- Newton shows that the "two-ness" of double refraction clearly rules out light being an ether wave. (All ether wave theories were sound-like, so Newton was right; longitudinal waves can't be polarized.)

1800- William Nicholson and Anthony Carlisle discover that water may be separated into hydrogen and oxygen by the action of Volta's pile.

1850 - Jean Foucault improves on Fizeau's measurement and uses his apparatus to show that the speed of light is less in water than in air.

1850- Stokes law is stated without proof by Lord Kelvin (William Thomson). Later Stokes assigns the proof of this theorem as part of the examination for the Smith's Prize. Presumably, he knows how to do the problem. Maxwell, who was a candidate for this prize, later remembers this problem, traces it back to Stokes and calls it Stokes theorem.

1850 - William Thomson (Lord Kelvin) invents the idea of magnetic permeability and susceptibility, along with the separate concepts.

1900 - Marie and Pierre Curie show that beta rays and cathode rays are identical.

1900 - Emil Wiechert shows that simply replacing the distributed charge from Lorentz's theory with the charge of a moving point particle gives incorrect results. Instead the Lienard-Wiechert retarded potentials must be used.

1900 - Joseph Larmor obtains the second order corrections to the Lorentz Transformation.

1901 - R. Blondlot performs experiments that show that Lorentz's theory in which there is no moving ether gives the correct result in cases where the hypothesis of a moving ether gives the wrong result.

1902 - Lord Rayleigh performs experiments to test whether the Fitz Gerald contraction is capable of causing double refraction in moving transparent substances. No such effect is found.

1903 - The Hagen-Rubens connections between the conductivity of metals and their optical properties are experimentally established.

1903 - Lorentz gives the famous square root formulas for the Lorentz transformation giving the effect to all orders in v/c .

1928 - Construction of Boulder Dam begins. Federal Trade Commission begins investigation of holding companies.

1933 - Tennessee Valley Authority (TVA) established.

1936 - Highest steam temperature reaches 900 degrees Fahrenheit vs. 600 degrees Fahrenheit in early 1920s. 287 Kilovolt line runs 266 miles to Boulder (Hoover) Dam. Rural Electrification Act.

1947 - Transistor invented.

1969 - National Environmental Policy Act of 1969.

1972 - Clean Water Act of 1972.

1975 - Brown's Ferry nuclear accident.

1977 - New York City blackout. Department of Energy (DOE) formed.

1978 - Public Utilities Regulatory Policies Act (PURPA) passed, ends utility monopoly over generation. Power Plant and Industrial Fuel Use Act limits use of natural gas in electric generation (repealed 1987).

1980 - First U.S. wind farm. Pacific Northwest Electric Power Planning and Conservation Act establish regional regulation and planning.

1984 - Annapolis, N.S., tidal power plant—first of its kind in North America (Canada).

1997 - ISO New England begins operation (first ISO). New England Electric sells power plants (first major plant divestiture).

1998 - California opens market and ISO. Scottish Power (UK) to buy PacifiCorp, first foreign takeover of US utility. National (UK) Grid then announces purchase of New England Electric System.

1999 - Electricity marketed on Internet. FERC issues Order 2000, promoting regional transmission.



AUTOMATIC CONTROL OF TIDAL POWER PLANT

Renewable energy can be used to decrease global dependence on natural resources, and tidal power can be the primary form of renewable power utilized. Built upon steam turbine knowledge, tidal turbines draw on innovative technology and design to operate on both the inflow and outflow of water through them. Tidal power utilizes twice the daily variation in sea level caused primarily by the gravitational effect of the Moon and, to a lesser extent by the Sun on the world's oceans. The Earth's rotation is also a factor in the production of tides.

Control & Operation system for tidal power plant should be simple, reliable, cheap and with minimum interference of operating personal. Control system should be such that remote operation can be performed easily. The main functions of the controller for automation is to execute starting and the shut down sequences under normal and emergency conditions. An attempt has been made to elaborate the use of Programmable Logic Controller (PLC) for control and automation of tidal power plant, its advantages and cost effectiveness.

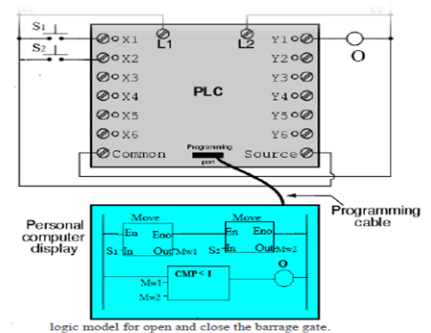
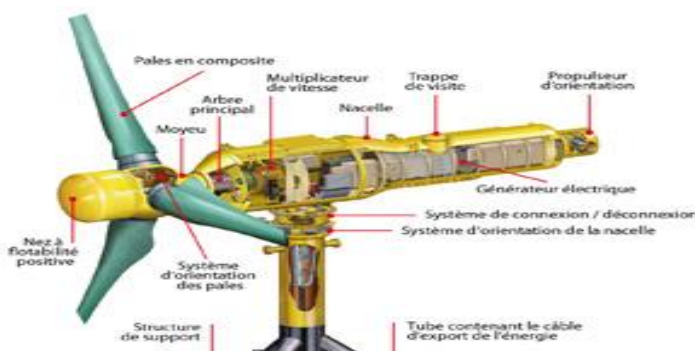

Programmable logic controllers (PLC) can be used for control & automation of tidal power plant. The main reason for this is cost effectiveness. Various functions and controls can be achieved by programming the PLC. They can be used for full plant automation including governing of auto-operation includes speed control, load control, excitation control, and level control automatic start/stop sequencing, barrage gate control, start/stop of auxiliary systems, and protection requirement etc.

Functions other than control like continuous monitoring, data recording, instrumentation and protections can also be performed. For remote operation, communication with PLC can be performed. For continuous monitoring purpose, a personal computer can be interfaced with PLC and continuous data can be recorded regularly

- VIGNESH KUMAR S, IV EEE 'B'

LIGHTNING PROTECTION SYSTEM BY RSM

A properly installed lightning protection system is over 98% effective in preventing lightning damage. It is a tried and true method that has been used for over one- hundred years. With the proper lightning protection system, you can rest assured that your investments, operations and personal will be protected. A lightning protection envelope is a complete system of strike termination devices, conductors, grounding electrodes, interconnecting conductors, surge protective devices, and connectors or fittings. The conductors safely conduct the lightning current to ground, and effective low resistance grounding helps to dissipate the lightning current into the earth. The practical purpose of a lightning protection system is the safeguarding of persons and property from hazards arising from the exposure to the dangers of lightning.

The rolling sphere method is the most used method to determine the protection zone for building and other facilities. In this method of determining the likely points of lightning strike attachment.

- (i) The sphere diameter corresponds to the last strike radius of selectable size of the lightning currents, as established by modern scientific testing and investigation.
- (ii) The areas touched by the sphere are deemed to require protection. On the tall structure, this can obviously include in the sizes of the facility. In addition, all possible placements of the sphere must be considered when determining the zone of protection using the rolling sphere method.

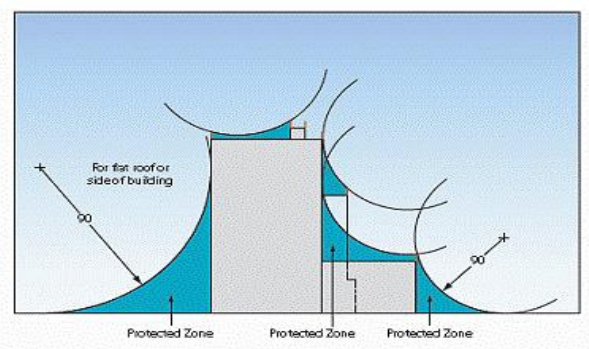
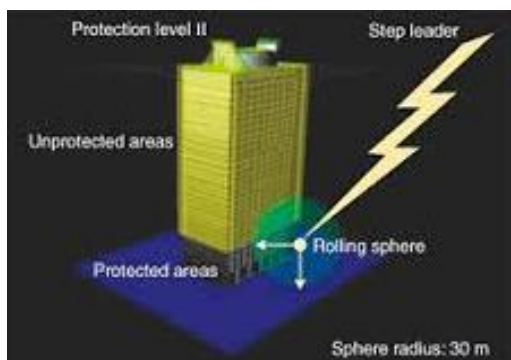

Lighting shielding analysis using the rolling sphere method can also be performed special software the red dots indicate the direct lighting strike point corresponding to rolling the sphere with radius 30m .this type of computer modeling aids in determining the required the num of lighting air terminals or protection measures to prevent direct lighting strikes to any elevated part of the structure .any available lighting protection standard may be used with corresponding protection level to determine the lighting air terminals required to protect the structure. -

-JAGADEESHAN D, III EEE

WIRELESS POWER TRANSMISSION

Would it not be better that your mobile or laptop gets charged without the use of wires? True that it may be the dream of many people especially those who come under the “Lazy people” category. But apart from this fact, the wireless power transmission can be loads better than the use of wires.

Wires can be a real messy job if not arranged properly. They may get entangled and lead to various problems. Like you may be disconnecting one appliance but accidently disconnect another because the wires are so much mixed that it is difficult to distinguish between the two wire sources. This may not be a problem at times but at others it can lead to huge errors and mistakes.

Power Can Be Transmitted Wirelessly In Three Ways:

Radio waves: these waves have been found able to transmit mill watts of power up to a distance of 15m. This technology is now being employed to recharge small portable device which include mobile phones and laptops.

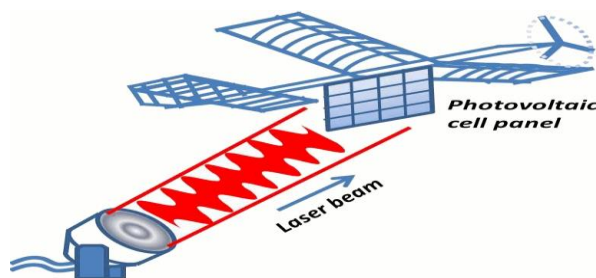

Lasers:

The use of Laser technology to transmit power wirelessly has so far shown only 15% efficiency. Beams of laser are targeted on photocells which convert the

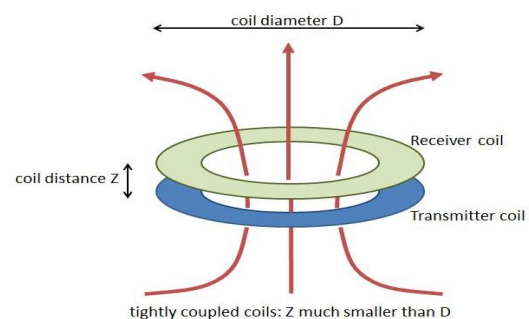

light energy into electrical energy and thus power is produced. So far, the application of this means stretches as far as lamps and speakers.

Magnetic Induction:

Both radio waves and lasers have applications only for the devices that require small amounts of power to operate. What about that requiring large amounts of electricity for such devices magnetic induction is used to transmit the power without using wires. The power loss during such a transmission is as much as 30%.

- NEVETHA B, III EEE'A'

NEW TECHNOLOGY FOR GRID LEVEL ELECTRICAL ENERGY STORAGE:

Nowadays, many industrialized nations are shifting to plan towards a sustainable future with efficient use of renewable energy sources. But electrical energy storage is the obstacle preventing more widespread use of renewable energy sources such as wind and solar power due to their unpredictable nature.

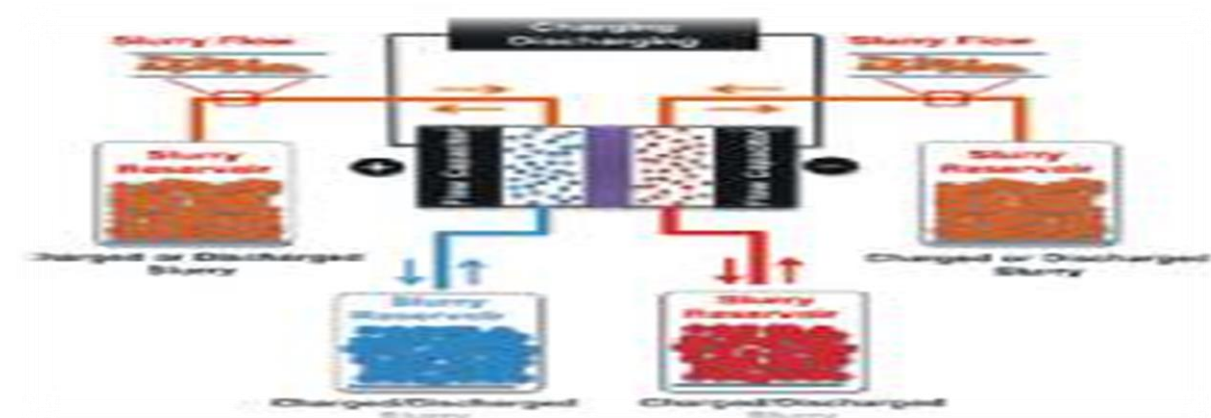

Whereas, on other hand conventional super capacitors, similar to lithium-ion batteries can provide a high power output with minimal degradation in performance and can rapidly store and discharge energy, but only in small amounts compared to the battery. The Drexel's team of researches is putting forward plan to integrate into the grid an electrochemical storage system that combines principles behind the flow batteries and super capacitors. "The electrochemical flow capacitor" (EFC) consists of an electrochemical cell connected to two external electrolyte reservoirs- a design similar to existing redox flow batteries which are used in electrical vehicles.

This technology is unique because it uses small carbon particles suspended in the electrolyte liquid to create slurry of particles that can carry an electrical charge. Uncharged slurry is pumped from its tanks through a flow cell, where energy stored in the cell is then transferred to the carbon particles. The charged slurry can be stored in reservoirs until the energy is needed. When energy is needed then entire processes reversed in order to discharge EFC.

- KAVIYA D,II EEE 'A'

ELECTRONIC NOSE

An **electronic nose** is a device intended to detect odors or flavors. Over the last decade, "electronic sensing" or "e-sensing" technologies have undergone important developments from a technical and commercial point of view. The expression "electronic sensing" refers to the capability of reproducing human senses using sensor arrays and pattern recognition systems. Since 1982, research has been conducted to develop technologies, commonly referred to as electronic noses that could detect and recognize odors and flavors.

The more commonly used sensors for electronic noses include

- Metal-oxide-semiconductor (MOSFET) devices - a transistor used for amplifying or switching electronic signals. This works on the principle that molecules entering the sensor area will be charged either positively or negatively, which should have a direct effect on the electric field inside the MOSFET. Thus, introducing each additional charged particle will directly affect the transistor in a unique way, producing a change in the MOSFET signal that can then be interpreted by pattern recognition computer systems. So essentially each detectable molecule will have its own unique signal for a computer system to interpret.
- Conducting polymers - organic polymers that conduct electricity.
- Polymer composites - similar in use to conducting polymers but formulated of non-conducting polymers with the addition of conducting material such as carbon black.

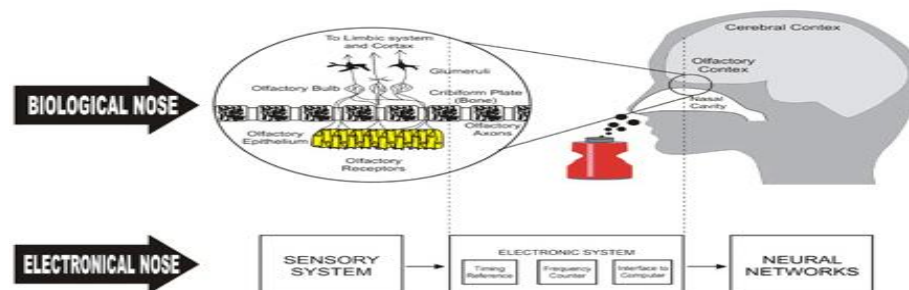

The computing system works to combine the responses of all of the sensors, which represents the input for the data treatment. This part of the instrument performs global fingerprint analysis and provides results and representations that can be easily interpreted. Moreover, the electronic nose results can be correlated to those obtained from other techniques (sensory panel, GC, GC/MS). Many of the data interpretation systems are used for the analysis of results. These systems include artificial neural network (ANN), fuzzy logic, pattern recognition modules, etc.

- NAVEEN KUMAR R II EEE 'B'

ELECTRIC MOTORS CROSS WORD

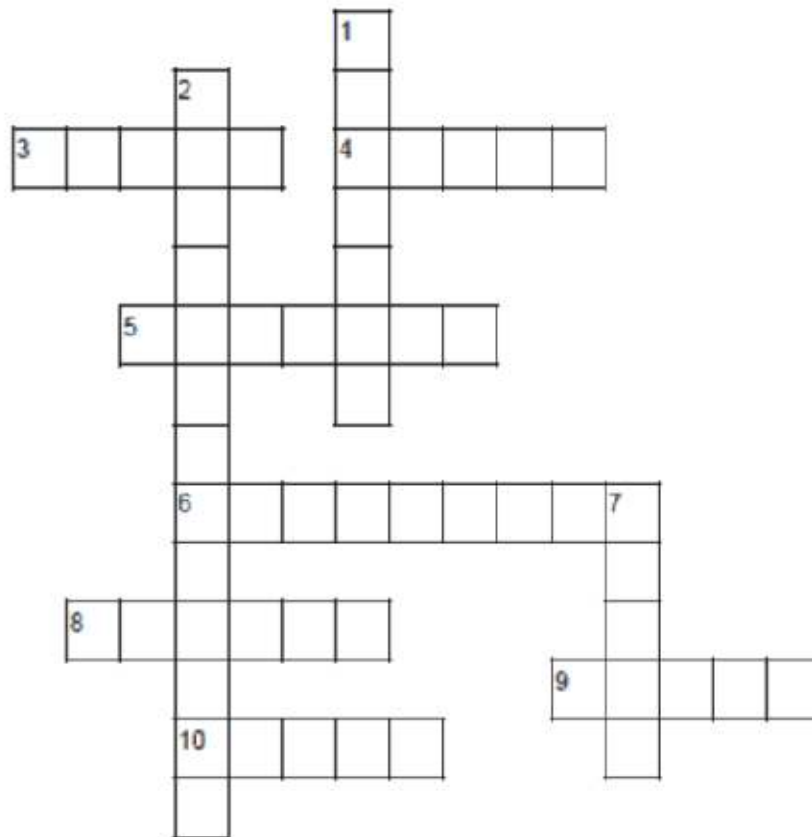

Across

3. There is a _____ magnetic around a magnet
4. When like poles come together they
5. When opposite poles come together they

6. An ability to attract or charm

8. When an object becomes magnetized and exerts magnetic force it is called a

9. The earth has a north and pole

10. The is a giant magnet Down

1. He invented the first electric motor (last name)

2. Is a magnet that work with electricity and can be switched on or off.

7. A small compact engine

- MATHAN J, IV EEE'B'

Innovative Articles



FRIEND SHIP THEOREM

Theorem:

Friendship = Heaven

Proof:

Friendship = Friend

Friend = College

College = Exams

Exams = Torture

Torture = Depression

Depression = Blood pressure

Blood pressure = Heart attack

Heart attack = Death

Death = Soul

Soul = Heaven

Thus LHS = RHS

Result:

Hence proved



Look at the sky. We are not alone. The whole universe is friendly to us
and conspires only to give the best to those who dream and work

-PRASANTH S IV YEAR 'B'

- FRIEND

Friend –The highest position in the world

No need for applications

No need for cover letters

No need for resume

No need for interviews

No need for hard work

No need to study well

Just look into the eyes with smile

And say Hai!!!!

It will give lots of happiness in the life



- GUNASEKARAN G , III EEE' C'

CURRENT LOVE

LOVE is electric, yes

When our heart beat becomes a pulse once,

I felt the stroke through my heart

Stars* turned radio active

It's the electricity that connect us and

It's the power discharge that disconnected us

We dance to vibration.

And we'll never stop,

Until gravity pulls us down from atmosphere

Spinning with protons and neutrons

Earthquake fuel our emotions

We touch and electrocute

When we are together, our souls are fused

You can't store our energy^, just like light

Lightning will strike when we kiss. 10000v surge in the night sky

Keeping us eternal and alive

*- she^- love



SANJEETHA M, III EEE

RUN TO WIN

Run run run until you can run,
But don't say I can't run.
Play play play until you can play,
But don't say I can't play.
Warner and Watson may play
In the series but the series is yours,
Play likes china and zaheer to hit some hot sand jake wickets,
Nadal and Serena may play against you,
Don't get frightened,
Because you are the next champion.
Bolt and P.T.Usha may be in the track next to you.
But the tracks where you are standing is yours, and
No one can come inside it to win you.
Rolando and messi may kick some penalties,
But you are the goal keeper,
Face the ball with courage and knowledge.



**Take risk: If you win, you will be happy; if you lose,
you will be wise**

RHYTHM OF FRIENDSHIP

A ring is round
It has no end
Such is my love
You a dear friend.
Sun rises in the east
And sets in the west
Friendship rises in the heart
And sets after death
Don't walk in front of me
For I shall not follow you
Don't walk behind me
For I shall not lead you
So walk with me
And be my true friend
In flower, rose is the reddest
In birds, parrot is the greenest
In nature, snow is the whitest
In friends, you are the dearest
Sitting up or sitting down
Friendship is the common noun
Present tense or past tense
Choose the friend with commonsense



PICHAI SUNDARARAJAN CEO OF GOOGLE



Pichai was born in Madras (now Chennai), Tamil Nadu, India in 1972 to Lakshmi and Raghunathan Pichai. His father was a senior electrical engineer in General Electric Company and managed a factory that made electrical components. Sundar grew up in a two-room apartment on 46th Street, 7th Avenue, in Ashok Nagar, Chennai.

Pichai completed his Class X at Jawahar Vidyalaya, Chennai and completed the Class XII from Vana Vani school located in the IIT campus, Chennai. Pichai earned his degree from Indian Institute of Technology Kharagpur in Metallurgical Engineering. He holds an MS from Stanford University in Material Sciences and Engineering and a MBA from the Wharton School of the University of Pennsylvania, where he was named a Siebel Scholar and a Palmer Scholar, respectively. Recently he was named the [Chief Executive Officer](#) of [Google](#). Pichai joined Google in 2004, where he led the product management and innovation efforts for a suite of Google's client software products, including Chrome and [Chrome OS](#),

Pichai joined Google in 2004, where he led the product management and innovation efforts for a suite of Google's client software products, including Chrome and [Chrome OS](#), as well as being largely responsible for [Google Drive](#). He went on to oversee the development of different apps such as [Gmail](#) and [Google Maps](#). On November 19, 2009, Pichai gave a demonstration of [Chrome OS](#) and the [Chrome book](#) was released for trial and testing in 2011 and released in public in 2012. On May 20, 2010, he announced the open-sourcing of the new video codec [VP8](#) by Google, and introduced the new video format [WebM](#).

On March 13, 2013, Pichai added [Android](#) to the list of Google products he oversees. Android was formerly managed by Andy Rubin. He was rumored to be one of the contenders for the CEO position of Microsoft in 2014. He was a director of [Jive Software](#) from April 2011 to July 30, 2013. Pichai was announced as the Product Chief by current CEO [Larry Page](#) on October 24, 2014. He stepped into the new position upon the

completion of the formation of [Alphabet Inc.](#), the new [holding company](#) for the Google company family.

- PRAVEEN KUMAR S, IV EEE

WINNERS, NOT QUITTERS.

1. A Small boy the fifth amongst seven sibblings of a poor father was selling newspapers in a small village to earn his living. He was not exceptionally smart at school but was fascinated by religion and rockets. The first rocket he built, crashed. A missile that he built crashed multiple times and he was mad a butt of ridicule. He is the person to have scripted the space Odyssey of India single handedly.

He is Dr. A. P. J Abdul Kalam.

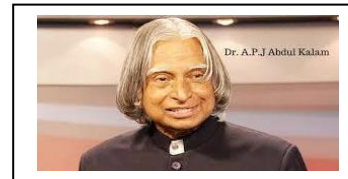

2. A Candidate for a news broadcasters post was rejected because of his voice He was also told that with his obnoxious long name, he would never be famous.

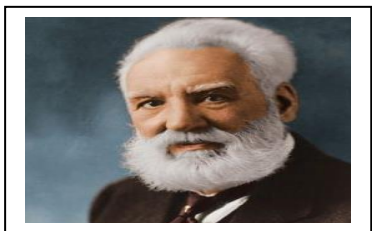

He said this to Alexander Graham bell.

3. A School teacher scolded a boy for not paying attention to his mathematics and for not being able to solve simple problems. She told him that he would not become anyone in life. His mother however believed in him and coached him in maths.

The boy went on to become Albert Einstein

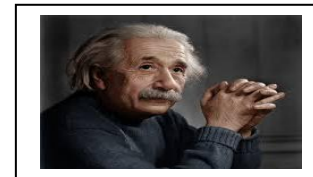

“A winner is not one who never fails, but one who never Quits”

SELF CONFIDENCE

The rebirth of Eagle.....

The eagle has the longest life-span of its species. It can live upto 70 years. But to reach this age the eagle must make a hard decision.

In its 40's

Its long and flexible talons can be longer grab prey which serves as food.

Its long and sharp beak becomes bent.

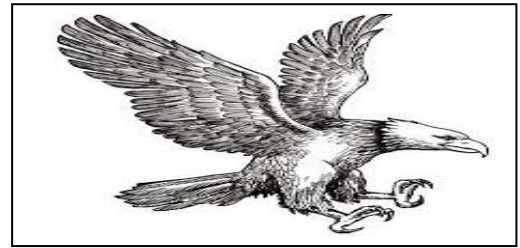

Its old aged and heavy wings, due to their thick

feathers, become stuck to its chest and make it difficult to fly.

Then, the eagle is left with only two options die or goes through a painful process of change which lasts 150 days.

The process requires that the eagle fly to a mountain top and sit on its nest.

There the eagle knocks its beak against a rock until it plucks it out.

After plucking it out, the eagle will wait for a new beak to grow back and then it will pluck out its talons.

When its new talons grow back, the eagle starts plucking its old-aged feathers.

And after five months, the eagle takes its famous flight of rebirth and lives for 30 more years.

Why is change needed?

Many times, in order to survive we have to start a change process.

We sometimes need to get rid of old memories, habits and other past traditions.

Only free from past burdens, can we take advantage of the present.

- KAVYA M ,IV YEAR 'A'

Drawings





- MILTON T T



- SNEHA S



THAARANI S



YASHIKA S